

## INTERNAL GEAR PUMPS - IG Series

### WORKING PRINCIPLE:

The Internal gear pump employs proven Internal gearing (Gear within gear) principle for pumping. As the gears come out of mesh, a partial vacuum is created, forcing the fluid to rush into the pump casing and fill in voids between teeth. Both gears rotating in the same direction of rotation gently transfer the fluid to the delivery port.

### MAIN APPLICATIONS:

- Loading, unloading, transfer, circulation and process pumping of a very wide range of products typically as thin as diesel oil to extremely high viscous substances
- Unloading of tank lorries and rail car
- Loading of rail cars, tank lorries and barrel filling

### LIQUIDS:

- Bitumen, coal, tar, crude oil, fuel oil, lacquer, linseed oil, lubricating oils, molasses, paint, etc.



INTERNAL GEAR PUMP

### PRODUCT SPECIFICATIONS AND FEATURES:

Rotors	Carbon Steel
Casing	Cast Iron
Pinion	Carbon Steel
Shaft	SS 410
Seal	Non Asbestos Gland Pack / Mechanical Seal
Capacity	70 - 800 lpm
Outlet Pressure	Up to 7 bar
Viscosity	40 - 1,00,000 cSt
Temperature	Up to 200°C
Speed	Up to 1450 rpm
Drive	Direct Only
Rotation	Anti-clockwise facing pump drive shaft

### VALUE PROPOSITIONS:

- Smooth quiet flow
- Excellent Self Priming
- Insensitive to viscosities
- Single sealing, external bearing
- Low noise and pulsation
- Reversibility
- Easy maintenance

### MARKET SEGMENTS:

- Food & Beverages
- Pharmaceutical
- Chemical

**CONSTRUCTION:**

Single shaft design well supported on outboard bearing enables to pump products even with poor lubricating value. The main gear is keyed to the drive shaft and rotates concentric in the pump casing. Idler is located on an eccentric pin on the front cover to rotate freely and meshes with main gear when assembled. A crescent shaped partition precision machined on the front cover, maintains a small but positive clearance to achieve perfect sealing between parts.

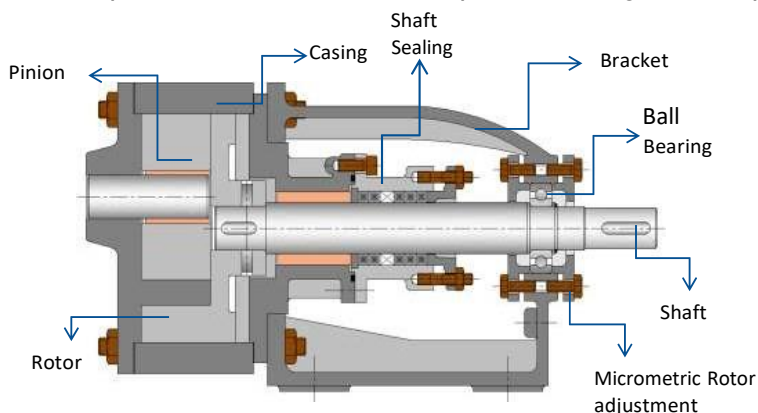

**PERFORMANCE DATA:**

Pump Model	Speed (rpm)	Capacity / Power	Pressure (bar)				Suction & Discharge
			0	2	4	6	
R-20-DG	1450	Capacity (lpm)	83	80	77	74	1-1/2" BSP
		Power (kW)	0.8	1.12	1.32	1.52	
TIG-100	960	Capacity (lpm)	230	224	220	217	2" ANSI,B16.5, 150#
		Power (kW)	2.9	3.45	5.20	6.1	
TIG-150	750	Capacity (lpm)	360	352	340	300	2-1/2" SAE
		Power (kW)	1.9	3.1	4.85	6.72	
TIG-200	480	Capacity (lpm)	368	362	352	342	3" ANSI,B16.5, 150#
		Power (kW)	3.1	3.15	5.52	8.19	

Testing medium: Lube Oil

Viscosity: 75 cSt

\* For special requirements, contact CIRCOR Sales Team

**Authorized Distributors: -**

**SAVIOUR PUMPS AND INDUSTRIES**  
**305, 3<sup>rd</sup> Floor, A-19, Shivam Building**  
**RDC Rajnagar, Ghaziabad – 201001**  
**Uttar Pradesh**

**Contact No. 7011197528, 7011197568**

**Mail ID [sales@saviourpumps.com](mailto:sales@saviourpumps.com) URL: <https://www.saviourpumps.com>**

**ALLWEILER INDIA PVT. LTD.**

LODHA iThink, 9th Floor, A wing  
 Off Eastern Express Highway, Behind Viviana Mall,  
 Chirak Nagar, Thane West, Maharashtra 400607 Tel.  
 +91-22-69197300  
 Email - salesho@circor.com

Chennai | Coimbatore | Daman | Kolkata  
 Mumbai | Noida | Pune | Secunderabad

